



# IN-GROUND FIXED MOUNT

## *FOR MARKET UMBRELLAS*

### ASSEMBLY GUIDE AND OPERATING INSTRUCTIONS



#### **PRODUCT CODE: 510541**

To register your product, go to [coolaroo.com](http://coolaroo.com). The product code can be found above. It is also shown above the barcode on the product packaging or on the relevant [coolaroo.com](http://coolaroo.com) web page.

For help with product assembly or for any other questions you may have, contact our Customer Service Department.

Australia toll free: 1800 331 521  
New Zealand toll free: 0800 555 171

[coolaroo.com](http://coolaroo.com)



Gale Pacific Limited  
145 Woodlands Drive, Braeside,  
Victoria 3195 Australia

Coolaroo is a registered trademark  
of Gale Pacific Limited.

Made in China



# ASSEMBLY GUIDE

## IN-GROUND FIXED MOUNT FOR MARKET UMBRELLAS

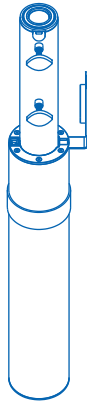

### STEP 1

Take all parts out of the box to ensure they are present.

(a) Aluminium in-ground mount



(b) Plastic cap (*already attached*)



(c) Wing bolts x2 (*packed inside mount*)



(d) Pole adaptors x5 (*packed inside mount*)



## STEP 2

Choose a suitable location for your umbrella in-ground mount ensuring there is enough space above and around to freely move the umbrella, and the ground is soft enough for a hole to be dug. Decide whether to secure the mount with concrete, soil, or sand and gravel. You will need these materials, along with a shovel and spirit level (not provided).

## STEP 3

Dig a hole in your chosen spot approx. 200x200mm wide by 550mm deep.

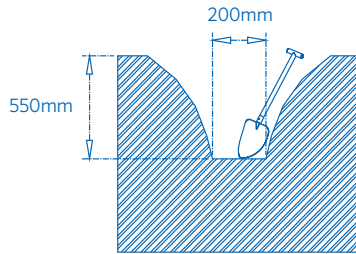

## STEP 4

Place the mount (a) into the middle of the hole and fill around it with cement, sand or soil, ensuring top of mount is perfectly level with the ground surface. The top plastic cap should be flush with the ground. Adjust as needed using the spirit level to check.

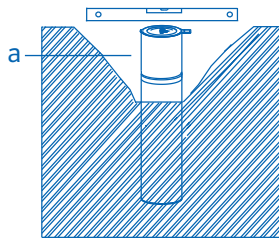

## STEP 5

Once concrete has set or mount is fully secure, open up the plastic cap (b) and remove the wing bolts (c). Carefully push switch to unlock the inner tube (stay clear as it may bounce up). Pull up inner tube and rotate it clockwise 90° until it locks into place.

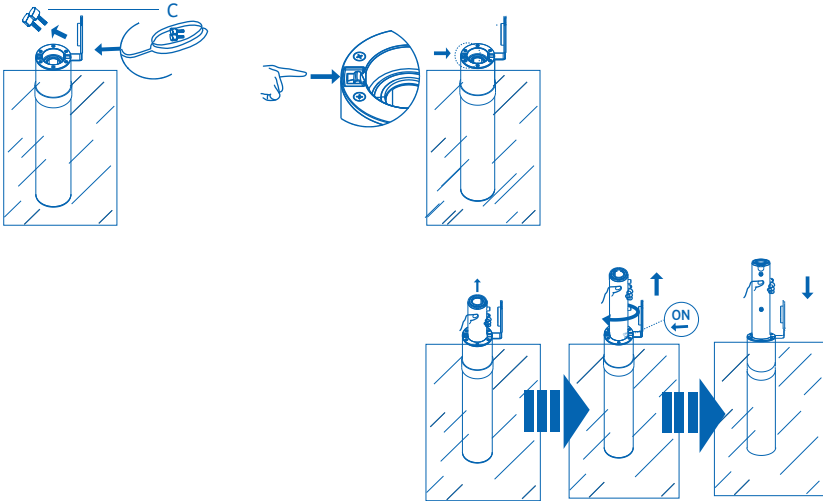

## STEP 6

Insert the wing bolts (c) into the two holes, but do not tighten yet. Select which of the included pole adaptors (d) fit best for your umbrella and insert into the inner tube. Eg. if your umbrella pole has a 35mm pole diameter, then you should use all pole adaptors larger than this size- 38, 48 and 52mm.

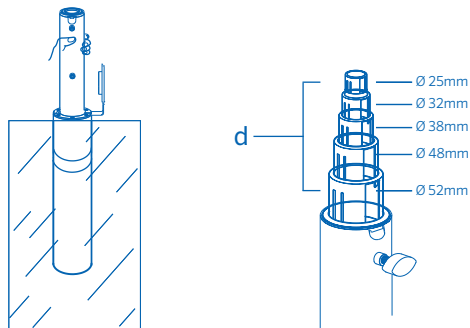

## STEP 7

Insert the correct pole adaptors into the inner tube if required. Insert your umbrella into the inner tube, then fully tighten the two wing bolts.

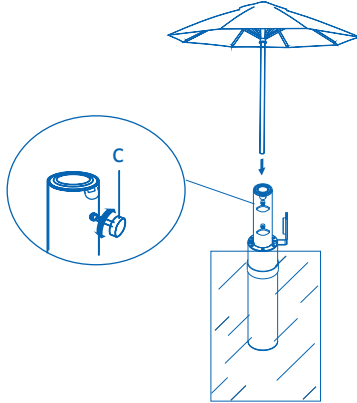

## STORAGE

To store the umbrella, remove it by first loosening the two wing bolts (c). These bolts can be stored in the plastic cap. Pull up the inner tube and turn it 90° anti-clockwise until the spring releases, then push the inner tube down back into the body of the mount. Finally close the plastic cap.

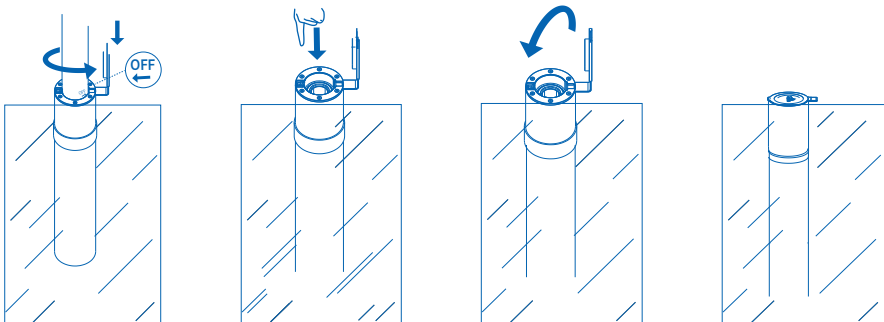

## PRODUCT WARRANTY AND LIMITATION OF LIABILITY

Coolaroo products are manufactured by Gale Pacific Limited ACN 082 263 778 (Gale). Gale provides the following warranty in relation to Coolaroo products ("Product").

The benefits of this warranty are in addition to any rights and remedies imposed by Australian Consumer Law, NZ Consumer Guarantees Act 1993, and state and federal legislation that cannot be excluded. Nothing in this warranty is to be interpreted as excluding, restricting or modifying any applicable legislation to the supply of goods and services which cannot be excluded, restricted or modified.

### WARRANTY

Gale warrants that, subject to the exclusions and limitations below, all parts of the manufacture and assembly of the Product will be free from defects in materials and workmanship for a period of one (1) year from the date of purchase.

If a defect appears in the Product before the end of the warranty period and Gale finds the Product to be defective in materials or workmanship, Gale will, in its sole discretion, either:

- a) replace or repair the Product or the defective part of the Product free of charge; or
- b) refund the purchase price of the Product.

Gale reserves the right to replace defective parts of the Product with parts and components of similar quality, grade and composition where an identical part or component is not available.

The warranty will not apply where:

- a) the Product has been altered or modified by someone other than Gale or its authorised agent;
- b) the alleged defect in the Product is within acceptable industry variances;
- c) Gale cannot establish any fault in the Product;
- d) the defect in the Product has arisen due to the customer's failure to install and use the Product in accordance with the instructions provided;
- e) the defect in the Product has arisen due to the customer's request to customise the Product;
- f) the Product has been subject to abnormal conditions, including environment, temperature, water, fire, humidity, pressure, stress or similar.

The warranty does not extend to:

- a) damage or defects caused by normal wear and tear,
- b) water or sun damage; or
- c) any other damage caused by the customer placing other equipment, furniture or material in close proximity to the Product.

Gale makes no express warranties or representations other than set out in this warranty.

The repair or replacement of the Product or part of the Product is the absolute limit of Gale's liability under this express warranty.

### WARRANTY CLAIMS

- 1) Upon purchasing the Product, the customer must register their warranty by completing the Coolaroo online warranty registration at [www.coolaroo.com](http://www.coolaroo.com). Alternatively, the customer can contact Coolaroo Customer Service on 1800 331 521 (AU) or 0800 555 171 (NZ) for assistance.
- 2) If a fault covered by warranty occurs, the customer must contact Gale using the contact details provided.
- 3) Any warranty claim must be accompanied by proof of purchase and details of the alleged defect.
- 4) The customer must bear the cost of the transport of the Product to and from Gale or the authorised agent to make the warranty claim, and all insurance of the Product.

### AUSTRALIAN CONSUMER LAW

Nothing in this agreement is intended to have the effect of contracting out of any applicable provisions of the Competition and Consumer Act 2010 or the Fair Trading Acts in each of the States and Territories of Australia, except to the extent permitted by those Acts where applicable.

This warranty is not transferable, and applies only to the initial purchaser of the installed Product.

In addition to the above warranty, Australian Consumer law and other state and territory legislation may imply warranties or conditions or impose liability on Gale in relation to the Product or its supply which cannot, or can only to a limited extent, be excluded, restricted or modified. Except for those implied warranties or conditions and such liability, and for the warranty described above:

- a) all warranties and conditions (whether express or implied, statutory or otherwise) relating to the Product or its supply are expressly excluded; and
- b) Gale will not be liable for any loss or damage suffered by any person (including the purchaser of the Product) in any way relating to or arising from the Product or its use (including loss or damage arising from the negligence of, or contributed to by, Gale).

If liability for breach by Gale of a warranty or condition or any other liability imposed on Gale by legislation which cannot be excluded may be limited, Gale's liability is limited to the extent permitted by law, and if liability may be limited in any one of a number of ways, Gale's liability is limited in any one of the permitted ways chosen by Gale in its absolute discretion.

The Purchaser acknowledges that the Purchaser does not rely on the skill or judgment of Gale as to whether or not the Products are fit for any particular purpose.

The Purchaser indemnifies Gale from every liability, loss, damage, cost or expense directly or indirectly incurred or suffered by Gale caused by or contributed to by the Purchaser's failure to:

- 1) adequately provide or display safety markings or safety information on or with the Products;
- 2) comply with any law about the Products or their use;
- 3) take any reasonable precaution to bring to the attention of any potential users of the Products any dangers associated with Products;
- 4) any negligence or breach of duty by the Purchaser or any breach by the Purchaser of these terms.