



## 2 INSTALLING THE BLIND

- Insert the clutch end of the blind onto the clutch unit bracket (**Fig. 3**) and the idle end into the idle end unit bracket (**Fig. 4**) until it snaps securely into place.
- Position the brackets to ensure the blind is held firmly between the brackets and tighten the screws.
- Install the bracket covers on to the brackets (**Fig. 5**).

### CONVERTING CLUTCH BRACKET TO SUIT LEFT-HAND CLUTCH CONTROL

Follow these steps to change the turbine around in the clutch to set it up for left hand operation.

- Slide off bracket cover.
- Remove the clutch assembly from the bracket by unscrewing the phillips head screws (**Fig. 6**).
- Remove the cover from the clutch assembly by unscrewing the phillips head screws (**Fig. 7**).
- Take out the turbine and refit it upside down (**Fig. 8**).
- Reassemble the clutch cover (**Fig. 9**) and bracket (**Fig. 10**) then refit the bracket cover.
- Remove the clutch and idle end plug from the end of the blind and swap them around (**Fig. 11**).

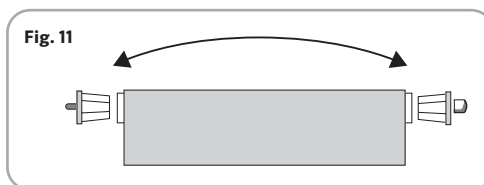
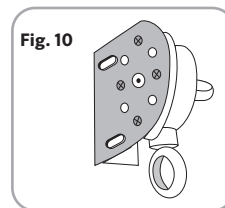
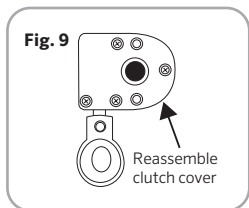
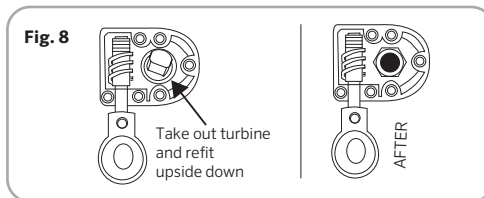
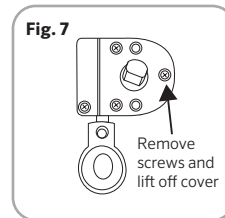
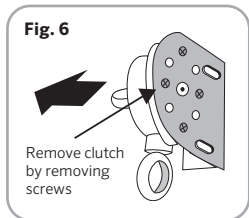
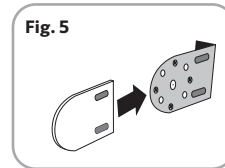
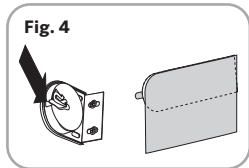
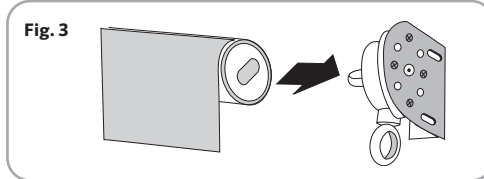

### CONVERTING BRACKETS TO SUIT TOP MOUNT

If you are installing your blind from the top remove the screws and rotate the clutch unit 90 degrees so the clutch eyelet points downwards (**Fig. 12**). Refit the screws and tighten.

Remove the screws and rotate the idle end unit (**Fig. 13**) so the opening is facing away from the window. Refit the screws and tighten.

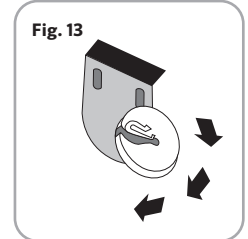
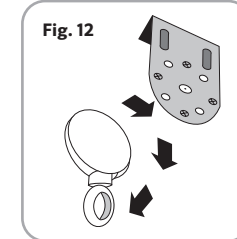

## 3 CRANK HANDLE OPERATION

First, assemble the crank handle using the screws and crank handle components, as shown.

Locate the hook on the crank handle through the eyelet on the clutch unit and use both hands to rotate the handle to adjust the blind up and down (**Fig. 14**).

**NOTE:** Remove and store crank handle when not in use.

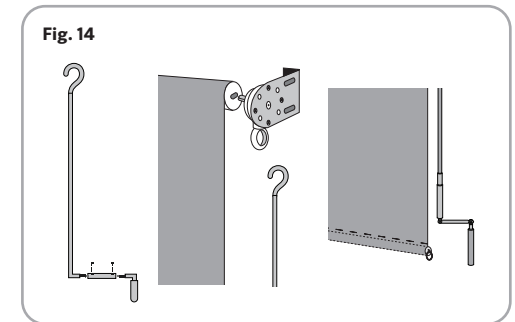

## 4 INSTALLING BUNGEE TIE DOWNS (optional)

Bungee tie downs have been provided to secure your blind in mild to moderate wind conditions.

- Thread the bungee through the end cap and back through itself making a lark's head knot (**Fig. 15**).
- Use the timber screws to install the receiver approximately 13cm (5") below where the blind will stop. Fit a receiver on each side of the blind (**Fig. 16**). Use the 5mm wall plugs if screwing into masonry.
- Attach the bungee to the receiver to secure the blind when in the down position.

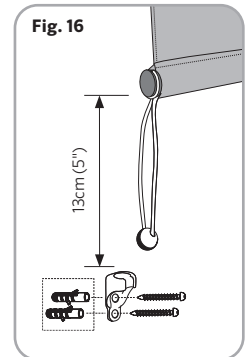
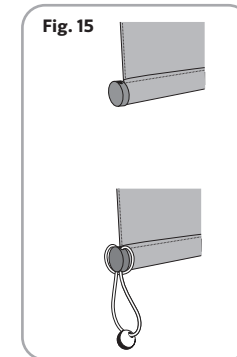

**i** Retract your exterior shade when not in use, or before strong storms, to prevent damage.

**MAINTENANCE:** Your exterior blind has been made of the finest materials and, when properly cared for, will provide years of shade, privacy and protection from the elements.

To clean your shade, simply rinse with water, scrub with mild soap or any non abrasive cleaner, rinse and allow to dry.

Do not store shade wet. In damp environments roll blind down frequently to air dry.

Retract your exterior blind when not in use, or before strong storms, to prevent damage.

**CAUTION:** Use of solvents or abrasive cleaners may damage the fabric and will void your warranty.

Do not use bleach or chlorine.